



Engineering
labeling solutions.

SL1500 Stepper Driven Label Applicator

St. Petersburg, FL. - Universal Labeling Systems announced the release of the SL1500 Modular Label Applicator.

- High performance stepper motor
- Label dispense speed up to 1500 inches per minute
- 6.375" web capacity (standard)
- 8.125" web capacity (optional)
- Photoelectric label sensing (standard)
- Clear label sensing (optional)
- Wipe on module (standard)
- 12" long peeler arm assembly
- Adjustable peeler bar assembly
- Tamp module (optional)
- Tamp Blow module (optional)
- Blow On module (optional)



The most universal of Universal Labeling Systems label applicators has truly perfected the modular approach to label applicators. In order to serve the needs of our customers, this modular style gives Universal the ability to provide a variety of applicator configurations "just in time."

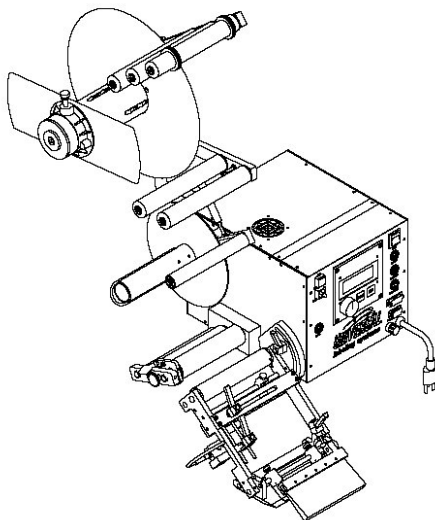

The new SL1500 features:

- *Label teach*, a quick and easy adjustment to the leading and trailing edge of varying label sizes.
- *Speed matching* that allows the exact control of speed and settings via a simple digital dial control.
- *Save Menu* providing the ability to save up to 99 different jobs.
- *Multi-level menu system* separating the operator interface from the set-up program, offering added production security.



2001 South 55th Street • PO Box 6145 • Omaha, NE 68106
Phone: (402) 556-7000 • Toll Free: (800) 255-7252 • FAX: (402) 556-6622



Engineering
labeling solutions.

The Modular Approach

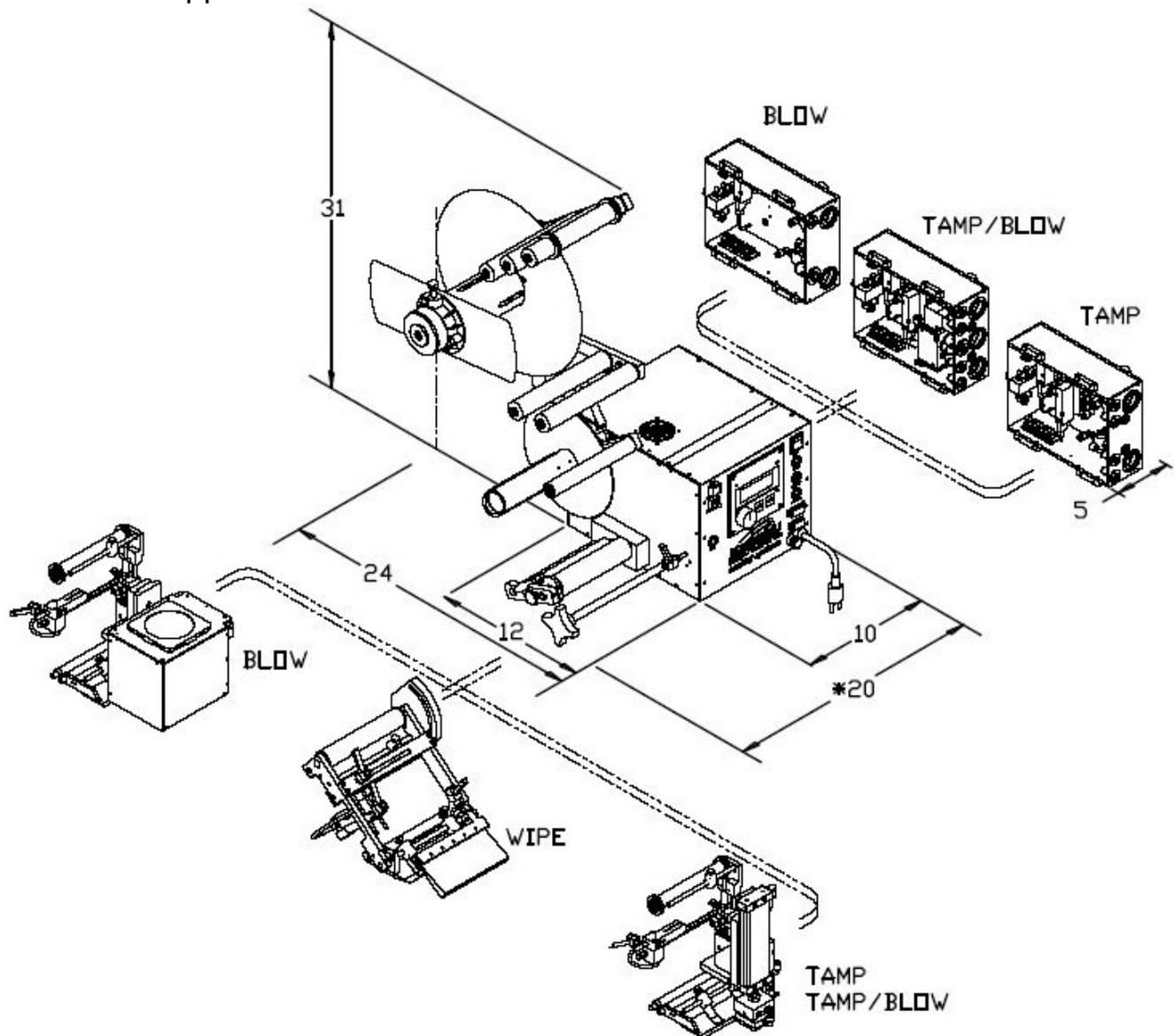

Universal is a leading provider of standard and custom labeling equipment. Our design of semi-automatic, automatic, and print & apply pressure sensitive labeling equipment makes us the most comprehensive manufacturer of labeling machinery in North America. Universal Labeling equipment is sold and supported through a world-wide network of authorized distributors.



2001 South 55th Street • PO Box 6145 • Omaha, NE 68106
Phone: (402) 556-7000 • Toll Free: (800) 255-7252 • FAX: (402) 556-6622